

# THURSDAY POOLS®

Your weekend starts early with us

## Aspen 1635 Depth: 3'-4" to 5'-6"

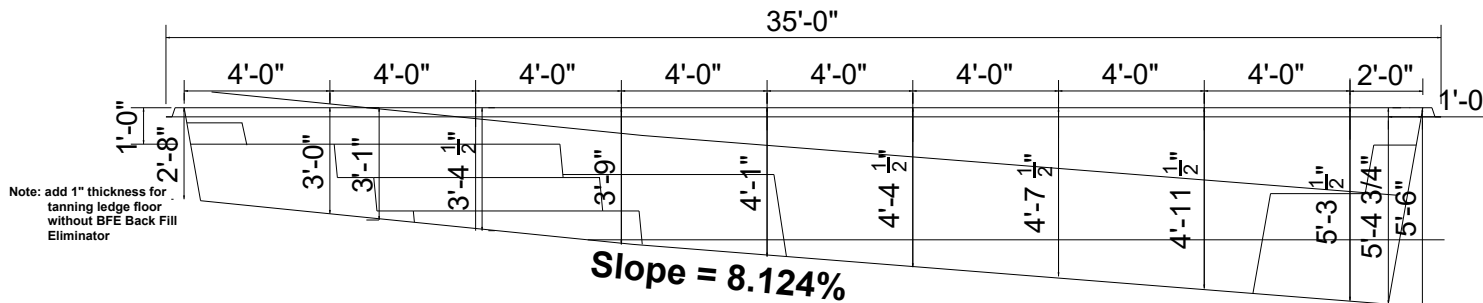
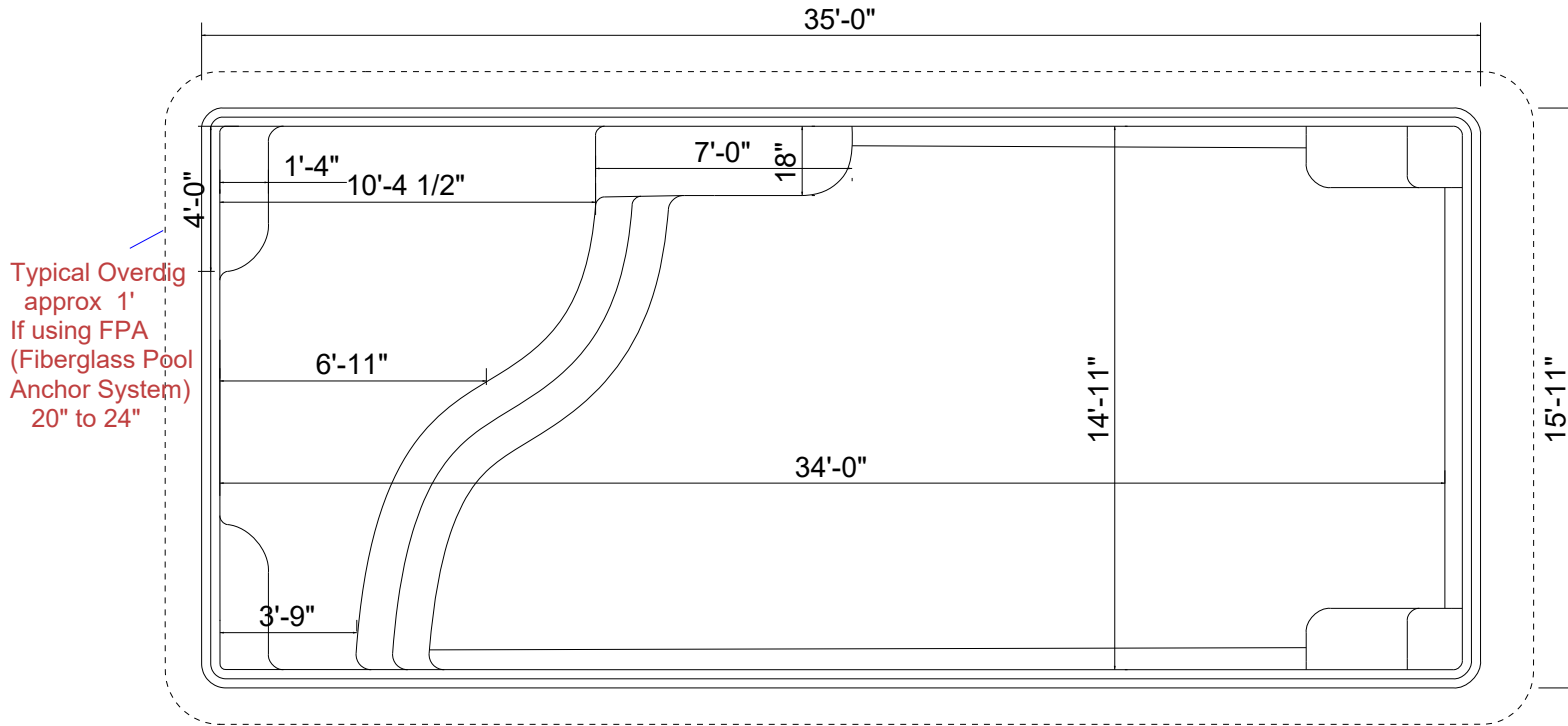

(Add approx 1/4" for fiberglass floor thickness and 1" for sun deck)

**PLEASE SEE GENERAL CONSTRUCTION AND RECOMMENDED INSTALLATION NOTES**

NON DIVING POOL

**THURSDAY POOLS, LLC**

your weekend starts early with us . . .  
840 Commerce Parkway  
Fortville, Indiana 46040  
Note: for technical help please call Thursday Pools LLC at  
Toll Free (877) 929-POOL (7665)  
Local (317) 973-0200

**CONTROL**

Meets Inlet Criteria WHK 2/25/17  
Confirmed Air Dim WHK 9/25/17  
Confirmed Dig Specs JH 3/25/18

**SPECIFICATIONS:**  
Volume: 10,140 gal (est)  
Weight: 2,300 lbs (est)  
Area: 505 sq. ft.(est)  
Perimeter: 98' (est)  
**SCALE:**

\*All depths reflect the depth of the pool structure.  
Water depths may vary depending on the amount of water in the pool.

This NOTICE AND DISCLAIMER is made to all retail customers, buyers, and end users of pools manufactured by Thursday Pools. You are by this NOTICE advised that pools manufactured by Thursday Pools (the "MANUFACTURER") are sold by independent dealers and dealerships. Each dealer is an independent businessperson who is completely separate from the MANUFACTURER. Each dealer is an independent contractor, and no dealer is an owner, agent (in fact or law), or employee of the MANUFACTURER. The MANUFACTURER hereby DISCLAIMS any liability for an intentional or negligent act by any dealer, dealership, or installer, or any damage to any Thursday Pools pool caused by an act of any dealer, dealership, or installer.

**General Tolerance +/- 1/2"**

To be filled out by C  
Date: 3/29/22  
Job No.  
File No.

To be filled out by Pool Dealer  
POOL NAME: Aspen 1635  
OWNER:  
ADDRESS:  
POOL DEALER:

Sheet No. D8  
Revision No. 01